

## Optical Transmittance Analyzer SL MD-220

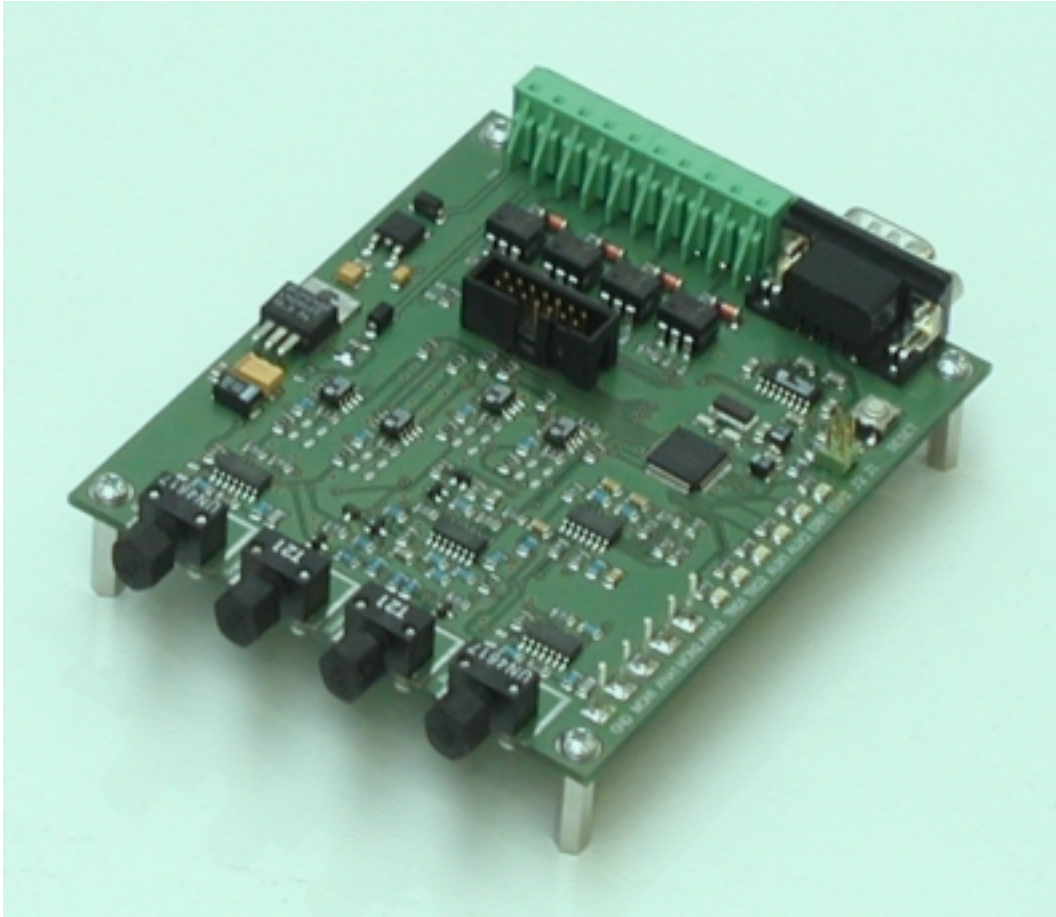

## USER'S MANUAL

Hardware Version 1.1b / Software Version 1.2

## Table of Contents

<b>1. General</b> .....	<b>4</b>
1.1 Introduction.....	4
1.2 Principle of Operation.....	4
1.3 Technical Data .....	5
<b>2. Hardware Section</b> .....	<b>6</b>
2.1 Dimensional Drawing.....	6
2.2 Handling Precautions .....	6
2.3 Installation .....	7
2.4 System Terminal.....	7
2.4.1 Mechanical.....	7
2.4.2 Connections .....	7
2.4.2.1 Power Supply Terminal.....	7
2.4.2.2 Optocoupler Outputs.....	8
2.4.2.2.1 Internal Circuitry .....	8
2.4.2.2.2 External Wiring .....	8
2.4.2.2.2.1 Generating Voltage Output Signals .....	8
2.4.2.2.2.2 Driving Loads .....	9
2.5 RS-232 Interface .....	9
2.5.1 Connector .....	10
2.5.2 Wiring.....	10
2.6 Reset Switch.....	11
2.7 Jumpers.....	11
2.8 Status LEDs .....	11
2.9 Measuring Pins.....	12
2.10 Fiber Optic Receptacles .....	12
2.11 JTAG connector .....	13
<b>3. Software Section</b> .....	<b>14</b>
3.1 General Description.....	14
3.2 Details .....	15
3.2.1 Startup Procedure.....	15
3.2.2 Timing .....	15
3.2.2.1 Program cycle time .....	15
3.2.2.2 Watchdog Timer .....	16
3.2.2.3 Trigger Timing .....	16
3.2.3 Jumper Settings .....	16

3.2.4	Status Outputs .....	16
3.2.4.1	Status LEDs.....	16
3.2.4.2	System Terminal Block.....	17
3.2.4.3	Status Table .....	17
3.2.5	RS-232 Interface.....	18
3.2.5.1	General.....	18
3.2.5.2	Comm Parameters.....	18
3.2.5.3	Output Modes .....	18
3.2.5.3.1	Voltage Mode .....	18
3.2.5.3.2	Percent Mode .....	19
3.2.5.3.3	Transmittance Mode.....	19
3.2.5.3.4	Status Mode .....	20
3.2.5.3.5	Off Mode.....	21
3.2.5.3.6	Software Version Query.....	21
3.2.5.3.7	Special Output Modes .....	21
3.2.5.4	Commands .....	21
3.2.5.4.1	System Reset Command.....	21
3.2.5.4.2	Threshold Reset Commands.....	21

## 1. General

### 1.1 Introduction

The SENSOR LINE MD-220 is a two-channel static opto-electronic interface for SENSOR LINE's SPZ/SPT fiber optic load sensors. This two-channel interface supplies light to two fiber optic sensors, monitors the amount of light transmitted through the sensors and detects small changes caused by loads applied to the sensors. With its advanced circuitry, the interface can detect a load on a sensor for as long as it is applied to the sensor.

The MD-220 incorporates a TI MSP-430 embedded microcontroller, programmable via a JTAG interface. It has a 10-wire screw-clip interface with power supply terminals and four floating optocoupler outputs. It also has a RS-232 interface for input and output of data. Direct external control is possible through the use of two jumpers and a reset switch. For quicker troubleshooting, six LED status displays show the function of the interface and there are five easily accessible test points for analog measurements.

Power consumption has been minimized by circuitry that operates the transmitter diodes in series while independently controlling the current through each diode. The MD-220 comes with two different kinds of transmitter diodes, a near infrared diode giving each channel a dynamic range of 30 dB and a more economic visible light diode for a dynamic range of 20 dB.

The hardware and software for the MD-220 comes in different versions. This manual is divided into a hardware and a software section.

**Please ensure that you have the correct version of this manual.**

### 1.2 Principle of Operation

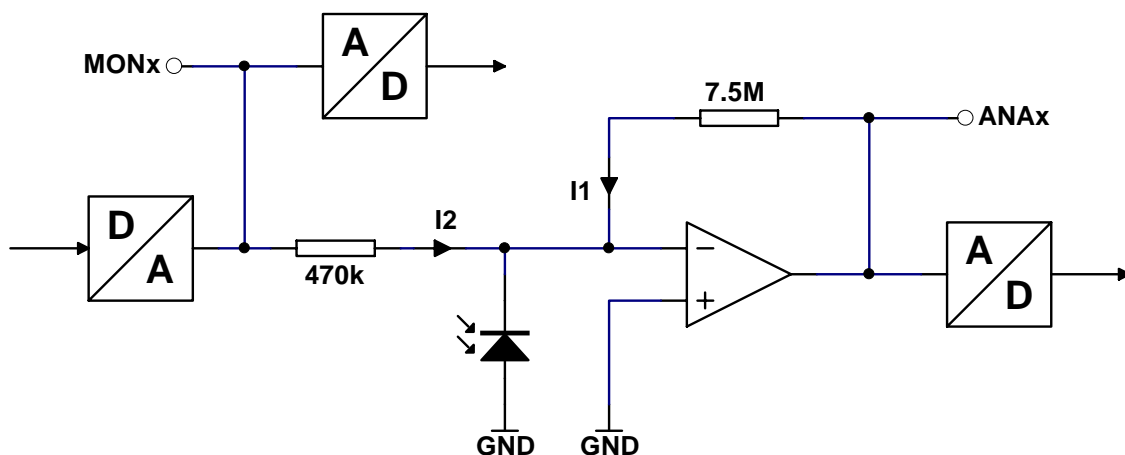

The drawing above is a simple circuit diagram of one channel. When the photodiode is illuminated with light from the sensor it proportionally sinks a current to the incoming light power. This causes the output of the OP to go high so the current is supplied across the 7.5M resistor. When the light becomes too bright the OP output is clipped, and the controller supplies additional current via the DAC and the 470k resistor until the OP output is "unclipped."

Small changes of photo current are amplified by the OP by a factor of 7.5 M $\Omega$  (7.5 V/ $\mu$ A). The controller measures this voltage ("Analog Voltage" or V<sub>ANAx</sub>) as well as the voltage produced by the DAC ("Monitor Voltage" or V<sub>MONx</sub>) with a resolution of 12 Bits. An additional DAC controls the light power fed into the sensor.

Both voltages can be measured at test pins. Since the sensitivity of the photodiode is about 0.5 A/W the incoming light power  $\Phi$  can at any time be calculated using the formula

$$\Phi = 2 \frac{W}{A} \cdot \left( \frac{V_{MONx}}{470k\Omega} + \frac{V_{ANAx}}{7.5M\Omega} \right)$$

### 1.3 Technical Data

Device Type:	MD-220	
<b>Hardware</b>		
Hardware Version:	1.1b	
Number of Channels:	2	
Size:	100x110x19 mm (3.54x4.33x.75 in)	
Electrical Connections:	10-wire screw terminal block RS-232, 3-wire 5 test points	
Optical connections:	SMA 905	
LED Peak Output Wavelength	850 nm (NIR) / 660 nm (VIS red)	
Maximum Sensor Loss:	30 dB (NIR) / 20 dB (VIS)	
Relative Humidity:	80% at 25°C (77°F)	
Temperature Range:	-40°C to 85°C (-40°F to 185°F)	
Supply Voltage:	+12 to +24 VDC	
Supply Current:	< 140 mA	
Analog Output at Test Points:	0-10 V	
Optocoupler Outputs max.:	OFF: 50V/<1uA ON: 5V/50 mA (250 mW @ 25°C)	
RS-232 connector	9-pin DSUB male	
Velocity Range:	1 to 250 km/h (0.6 to 155 mph)	
Feeder Length:	up to 250 meters (820ft)	
Comparative Laser Class:	3A (NIR, sensor disconnected)	
EMV/EMI:	Meets CE-requirements	
<b>Software</b>		
Program Name:	MA220STD	
Program Version:	1.2	
Program cycle time:	500 $\mu$ s $\pm$ 5%	
Watchdog expiration time	4 ms	
Triggering	Threshold	0.8% change of light transmittance
	Hysteresis:	$\pm$ 2 digits
	Minimum input ON time:	3 program cycles (1.5 ms)
	Minimum output ON time:	3 program cycles (1.5 ms) / 40 program cycles (20 ms)*
	Maximum output ON time:	30 s
RS-232	Baud Rate	9600 Bd / 19200 Bd**
	Data Bits	8
	Stop Bits	1
	Parity	N (no parity)

\* with jumper J1 shorted, \*\* with jumper J2 shorted

## 2. Hardware Section

The PCB version is found on the bottom layer of the PCB. This manual is for hardware version 1.1b.

### 2.1 Dimensional Drawing

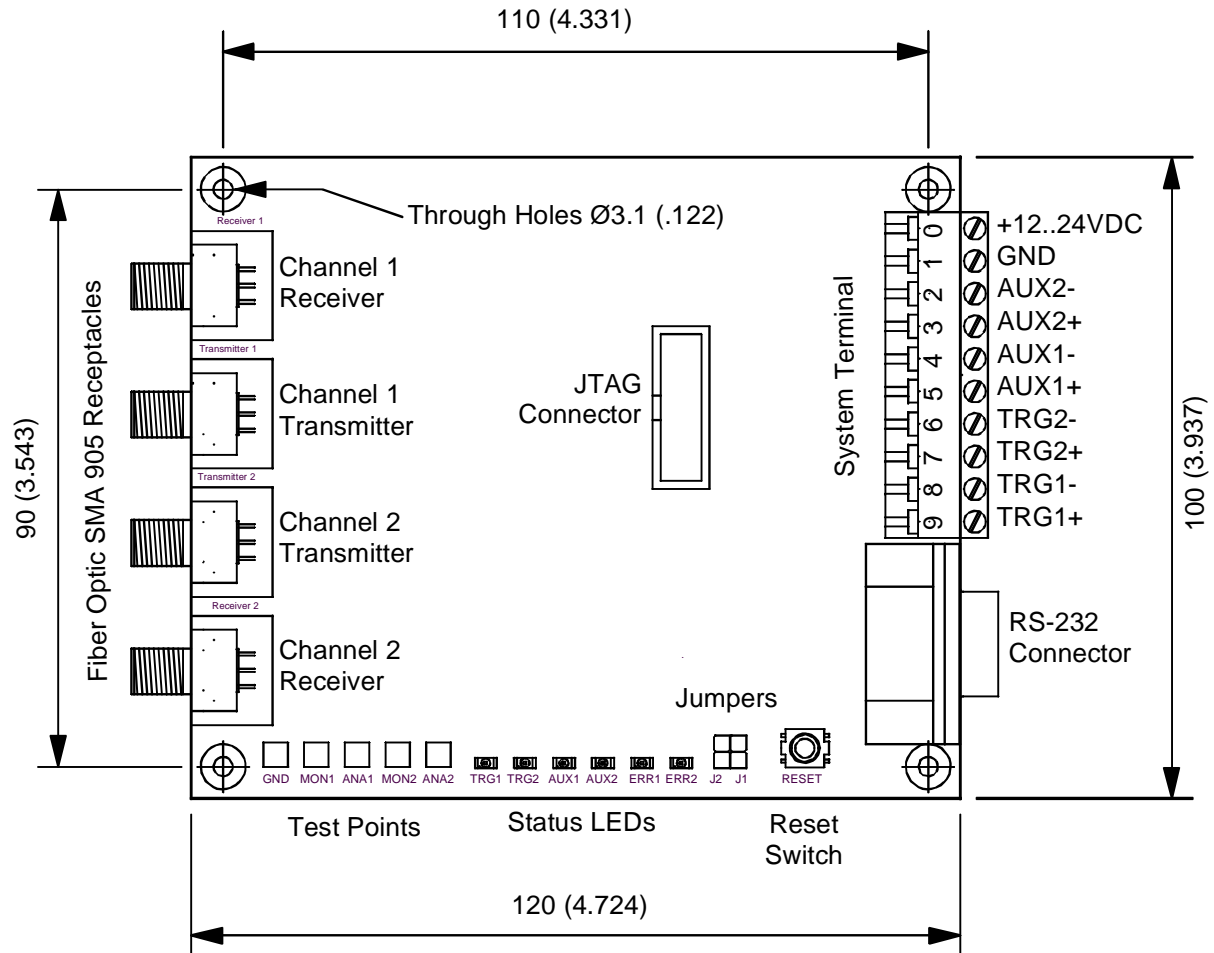

Maximum Height 19 (.748) - Dimensions in mm (in)

### 2.2 Handling Precautions

The MD-220 is delivered without a housing so handle it the same way as a PC card. Some of the interface components are sensitive to electrostatic discharge (ESD). Leave the interface inside its conductive bag until installation. Discharge yourself by touching a grounded conductor before touching the interface. The receptacles are either non-conductive or grounded and the system outputs have a special protective circuitry. It is relatively safe to handle the interface by these parts. If conductive spacers are used, the interface may be handled by these spaces because the rims of the through-holes are also grounded. Before pressing the reset switch by hand first discharge yourself. The jumpers and LEDs are connected directly to the controller and should never be touched. The test points are connected to OP outputs, which are also sensitive to ESD. Discharge any measuring clips on the GND pin before contacting one of the other test points.

## 2.3 Installation

The MD-220 PCB has four Ø3.1mm (0.12") through-holes, allowing it to be mounted on any appropriate flat surface by means of M3 screws. At least 5mm (0.2") spacers are recommended to ensure a sufficient gap between the PCB and the mounting surface.

## 2.4 System Terminal

### 2.4.1 Mechanical

The system terminal is a 10-wire screw terminal block which accepts 0.14–1.5 mm<sup>2</sup> (26–16 AWG) wires. To fasten the screw clips a screwdriver with a blade up to 3.5 mm wide can be used. The terminal block can either be a flat or angled design, the latter is used if several interfaces are stacked.

### 2.4.2 Connections

Pinning	Sign	Description
0	+12...24VDC	Supply Voltage
1	GND	Ground
2	AUX2-	} Auxiliary Optocoupler Output 2 (Low Resistance = Sensor Failure)
3	AUX2+	
4	AUX1-	} Auxiliary Optocoupler Output 1 (Low Resistance = TRG1 <b>AND</b> TRG2)
5	AUX1+	
6	TRG2-	} Trigger Channel 2 Optocoupler Output (Low Resistance = Load Response)
7	TRG2+	
8	TRG1-	} Trigger Channel 1 Optocoupler Output (Low Resistance = Load Response)
9	TRG1+	

#### 2.4.2.1 Power Supply Terminal

Terminals 0 and 1 of the system terminal block are for connection of a 12-24 VDC power supply. The MD-220 has built-in voltage regulators and is reverse voltage protected. The interface draws a maximum of 140 mA. Connect the negative output to Terminal 1 and the positive output to Terminal 0.

### 2.4.2.2 Optocoupler Outputs

#### 2.4.2.2.1 Internal Circuitry

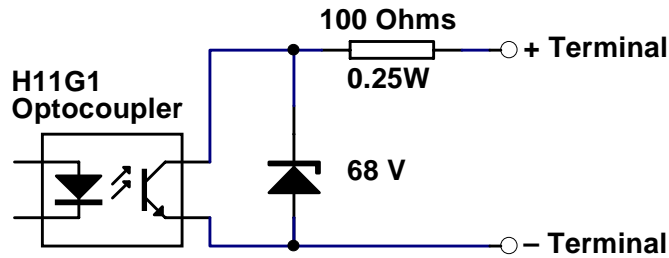

The above schematic shows the internal circuitry of the TRG1 & 2 and AUX1 & 2 optocoupler outputs. When the phototransistor is illuminated by the LED (ON condition) current flows into the + terminal and out of the - terminal. The resistor limits the maximum allowable current to 50mA. Therefore, any DC voltage applied directly to the outputs must not exceed 5V when the phototransistor is conductive because the maximum power the 100 Ohm resistor can dissipate is 250mW.

When the phototransistor is not conductive the maximum voltage is limited by the zener diode to 68V. If a voltage above that value is applied (even with additional resistors), the output might appear conductive but the phototransistor is not. To avoid any glitches caused by voltage spikes or surges the optocoupler outputs should not be operated with voltages above 50V.

#### 2.4.2.2.2 External Wiring

The optocoupler outputs are not connected to any voltage source so there are many ways to obtain various kinds of output signals. In all cases an external power supply must be added. The outputs behave as switches with the restriction that current can only flow in one direction. Below are examples of how the outputs may be wired.

##### 2.4.2.2.2.1 Generating Voltage Output Signals

Voltage output signals are required if high impedance inputs, like those on an oscilloscopes, are connected. The wiring from the diagrams below can be used if the voltage from the available source has the required value or is not critical.

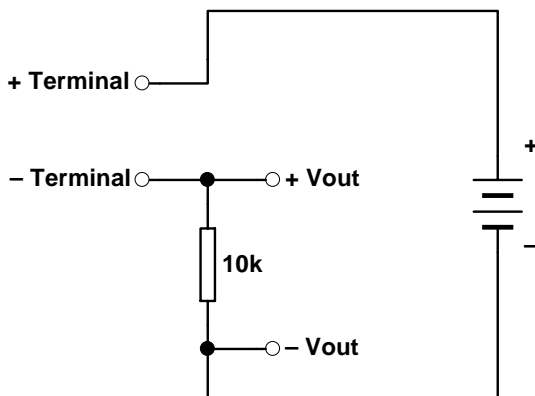

Zero output voltage going HIGH on ON condition

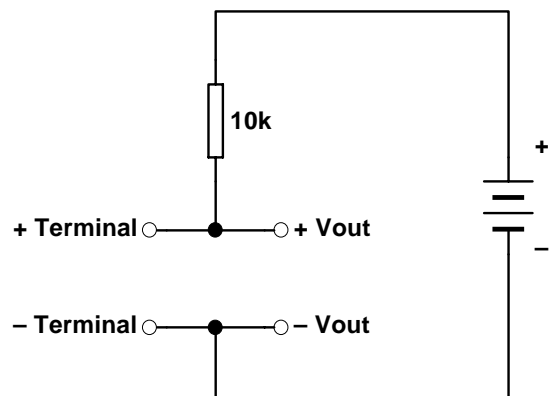

Positive output voltage going LOW on ON condition

If the voltage available is too high for the intended inputs a second resistor must be added in order to create a voltage divider as given in the schematics below. It is generally safe to choose resistors in the range of 10kΩ.

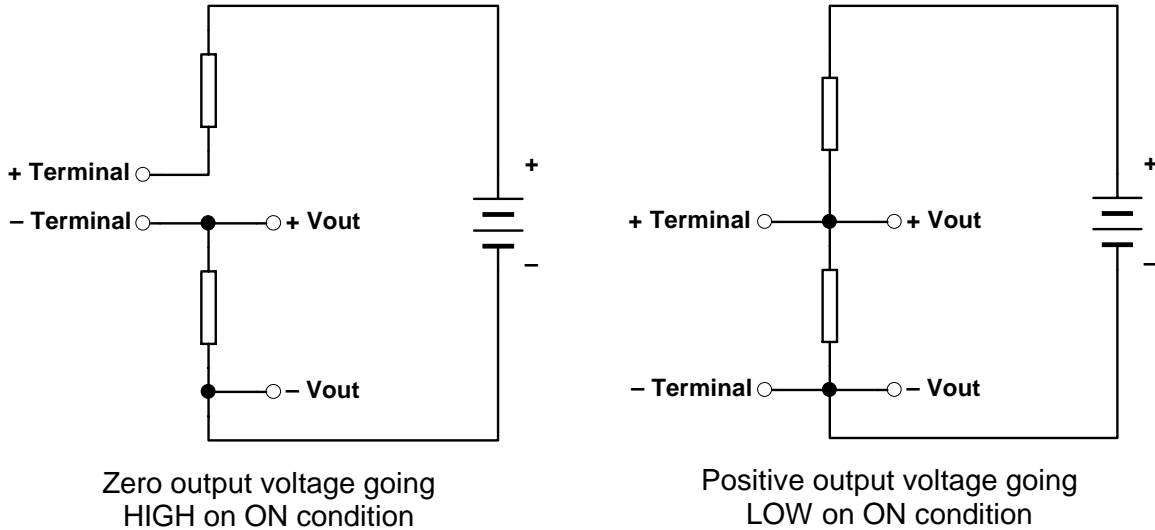

**2.4.2.2.2 Driving Loads**

When there are no high impedance inputs that inhibit the flow of current it is not necessary to generate a voltage. In this case the optocoupler output can be used as a switch to turn current on and off. The wiring below shows how to operate an LED or drive optocoupler inputs or relays. The current must be limited to a maximum of 50mA with an appropriate resistor.

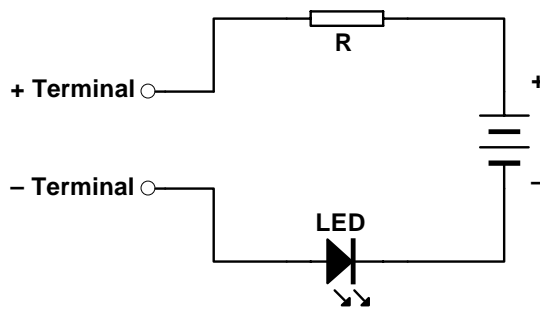

Driving a LED

**2.5 RS-232 Interface**

The MD-220 has a three-wire RS-232 interface with a male 9-pin DSUB RS-232 connector. It behaves like a PC, sending data on the TXD line (Pin 3) and receiving on the RXD line (Pin 2). It can be connected directly to a printer with a standard RS-232 cable. To connect it to a PC a null-modem cable is required, similar to the connection between two PCs.

Please refer to the software section for the communication parameters as baud rate, parity, etc.

### 2.5.1 Connector

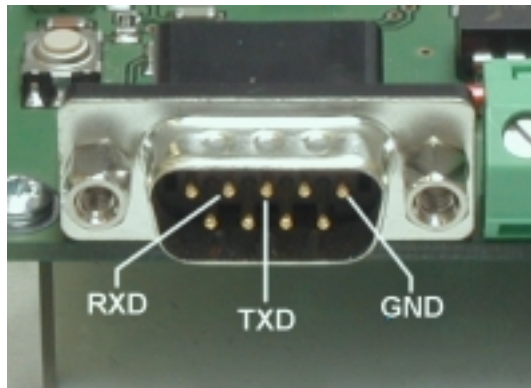

### 2.5.2 Wiring

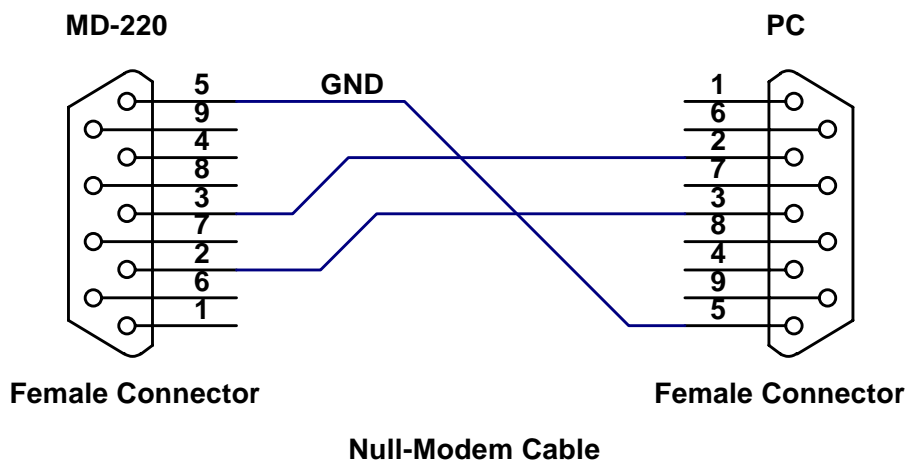
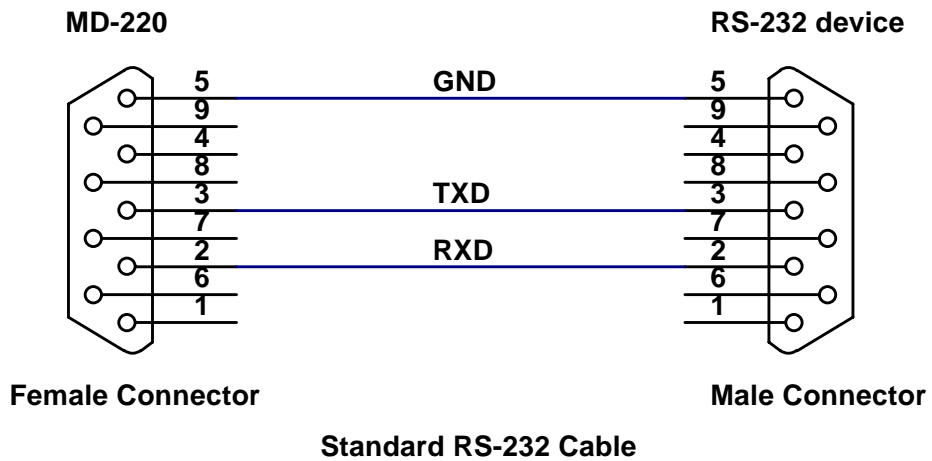

## 2.6 Reset Switch



Pressing the reset switch causes a hardware reset of the microcontroller.

## 2.7 Jumpers

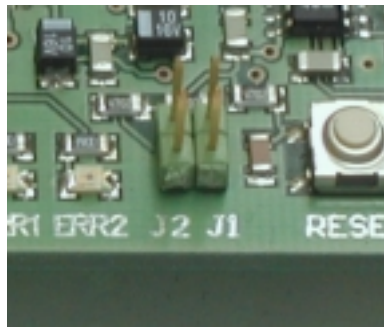

The jumpers J1 and J2 are connected to I/O pins of the microcontroller. They are used to signal different conditions in order to modify the behavior of the interface without re-programming it. They can also be used as I/O connections for special purposes. Please refer to the software section of this manual for the different jumper settings.

## 2.8 Status LEDs

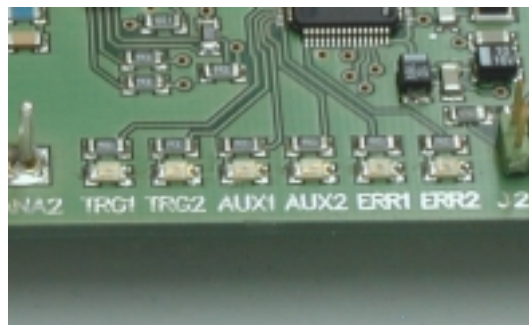

There is a display of six LEDs controlled by the microcontroller. TRG1, TRG2, AUX1 and AUX2 are yellow, and ERR1 and ERR2 are red. Please refer to the software section of this manual for the meaning of the LED signals.

## 2.9 Measuring Pins

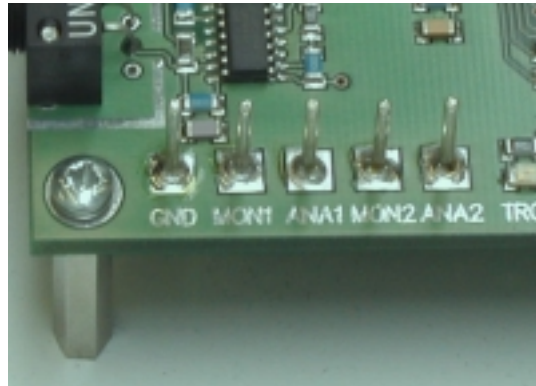

There are five test points with 1.3mm (0.05") pins for measuring the analog voltages evaluated by the microcontroller. The meaning of these voltages is thoroughly explained in paragraph 1.2 on page 4.

Label	Signal	Sign
GND	Ground	—
MON1	Monitor Voltage Channel 1	$V_{MON1}$
ANA1	Analog Voltage Channel 1	$V_{ANA1}$
MON2	Monitor Voltage Channel 2	$V_{MON2}$
ANA2	Analog Voltage Channel 2	$V_{ANA2}$

## 2.10 Fiber Optic Receptacles

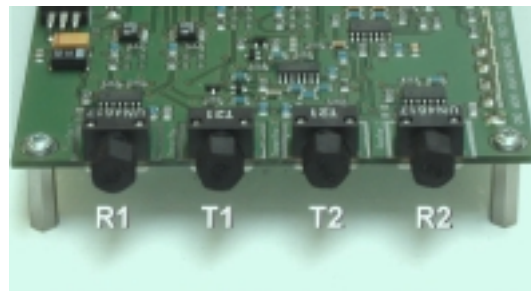

Two fiber optic load sensors can be connected to the MD-220 via four SMA 905 fiber optic receptacles. Viewed from the front the receptacles for Channel 1 are on the left hand side and those for Channel 2 on the right hand side. The transmitters are the inner receptacles.

**Do not stare into the transmitters when the interface is powered and there is no sensor connected.**

Fasten the sensor's fiber connectors to the transmitter or receiver by screwing tightly on by hand (the tighter, the smaller the attenuation). **DO NOT USE PLIERS.** The transmitter and receiver connectors are interchangeable for each channel. The transmitter connectors are **not** interchangeable i.e. a sensor connected for example to Transmitter 1 and Receiver 2 will not work.

## 2.11 JTAG connector

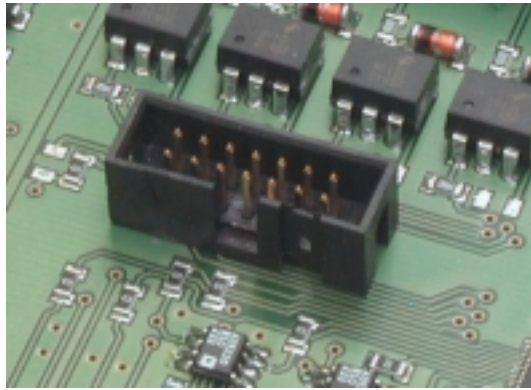

The JTAG connector is used for programming the microcontroller at the factory. If you are planning to re-program the device in the field please contact Sensor Line GmbH for further information.

### 3. Software Section

The following refers to the MD-220 program MA220STD version 1.2.

#### 3.1 General Description

The program executed by the microcontroller controls all functions of the MD-220. Detecting a load applied to the sensor is difficult because of the large variation in sensor transmittance versus the small amount of transmittance change when load is applied. For example, if the sensor transmittance could change by a factor of 100 (20 dB) and the transmittance change caused by a load was 1% ( $=1/100$ ) the complete light measuring range would have to be resolved to  $1/10000$  of its value in order to detect the load. This is more than twice the resolution of a 12-bit ADC.

To overcome this difficulty the microcontroller controls the photo currents detected by the input amplifiers in two ways. First, it can vary the transmitter currents by a factor of ten. Second, it can subtract an offset of up to 16 times the range of the amplifiers from their input current. With growing sensor transmittance the light power fed into the sensors is reduced in order to avoid clipping of the signal. When the minimum value is reached the controller compensates for further increases in sensor transmittance by subtracting increasing portions of the photo current before the remainder is fed into the amplifiers (see paragraph 1.2 on page 4).

After startup the program uses these methods to adjust the amplifiers' output voltages (called "analog voltages") to a value in the upper region of the ADCs' measuring range. Then it establishes a threshold below that value corresponding to a constant fraction of the light detected. After this initialization process the program enters its main loop. Here it monitors the analog voltages and checks if they have dropped below the threshold values, thus signaling load being applied to the sensors.

As long as there is no load detected the thresholds are carefully adapted to slow changes (drifting) of the detected light and the analog voltages are adjusted, if necessary. However, if there is load this process cannot be continued since it is impossible to determine whether a change of the detected light is due to drifting or due to a change of the load. As equipment does not stop drifting when there is load on the sensor the interface cannot be allowed to detect load for infinite time. If during load detection the amount of light detected without any load drifted below the stored threshold, the interface would no longer be able to notice the load being removed; it would "hang".

For this reason there is a maximum detection time of 30 seconds. When this time has elapsed, the interface performs an initialization process similar to the one at startup. The interface is then ready to detect additional load being applied to the sensor. The original load effect is regarded as intrinsic sensor attenuation. When the original load is removed the threshold is adapted immediately.

When the sensor is broken (or disconnected) no light arrives at the receiver and the interface is unable to detect any load. If the sensor fails during operation, the detected light falls below the threshold and is reported as load being detected. Therefore, sensor failure during operation is first reported as a load detected, and it changes to an error signal after 30 seconds.

## 3.2 Details

### 3.2.1 Startup Procedure

After power-up or when a program reset is initiated the MD-220 first tries to adjust itself to the particular sensors attached. This process takes about one second and is signaled by both ERRx LEDs (see paragraph 3.2.4.1 on page 16) flashing at 8 Hz.

If insufficient light is detected, i.e. if there is no sensor connected to a channel or the connected sensor is broken, the respective ERRx LED comes on continuously along with the AUX2 LED. The AUX2 optocoupler output becomes conductive and the associated TRGx LED flashes ten times at 2 Hz. The TRGx LED is then switched off.

In the case that there is too much light detected (which may happen when an interface with infrared transmitters is used in conjunction with a low loss sensor) the ERRx and AUX2 LEDs and the AUX2 optocoupler outputs behave the same way but the TRGx LED does not flash.

If the sensor loss is within a range where the interface can successfully adjust itself the program waits for the transmitter to stabilize its output power. This is necessary because during power-up the transmitter becomes warm, causing a slight decrease in its brightness during the first few seconds.

Since it is not possible to derive a measure for the sensor loss from the analog voltages at the test pins, the interface signals the virtual sensor loss during warmup time. It cannot determine the real sensor loss. Rather, the sensor loss, in this, cases, defines a certain value within an internal "theoretic" dynamic range of 30 dB. For a number of reasons this range can not be fully utilized in practice but the interface "sees" the loss of the sensors vary within it. In order to express this virtual sensor loss the internal dynamic range is divided into ten intervals of 3 dB. While the transmitter is warming up the TRGx LED of each channel is flashed from one to ten times. The number of times it flashes multiplied by 3dB is the virtual sensor loss. If a sensor has high loss, the transmitter needs more time to warm up because it is operated at high power.

The number of times the TRGx LEDs flash can not be directly translated into sensor loss since it is given with respect to that particular channel's dynamic range. Dynamic range may vary due to variations of the opto-electronic components. However, it shows how that particular sensor is handled by that interface channel. If the TRGx LED flashes at least two times and no more than nine times during the warmup time there is at least a 3 dB reserve and operation can generally be considered to be safe, regardless of the exact sensor loss and the particular interface used.

As long as the sensor loss is signaled by flashing TRGx LEDs, the ERRx LEDs continue flashing at 8 Hz, showing the warmup time has not yet expired and the interface is not yet operational. After the ERRx LEDs are switched off and the TRGx LEDs are continuously on the startup process is complete.

### 3.2.2 Timing

#### 3.2.2.1 Program cycle time

The main loop of the program is executed during a constant time interval of approximately 500  $\mu$ s. This time can vary about  $\pm 5\%$  due to the tolerance of the clock oscillator. All quantities are updated at every cycle. The time resolution of the interface is therefore equal to the program cycle time.

### 3.2.2.2 Watchdog Timer

The watchdog timer is serviced every time the main loop is executed. Its time interval is set to 4 ms. If the program hangs for whatever reason and this time expires a program reset is performed.

### 3.2.2.3 Trigger Timing

The trigger function works with a threshold that has a hysteresis of only  $\pm 2$  digits. This is just sufficient to prevent the interface from bouncing due to the sheer quantization error of the ADC. Debouncing is done by requiring a valid load pulse have at least 3 program cycles (1.5 ms) of duration. This requires that the trigger delay also be 1.5 ms. The output pulse duration is correct because switching off and on is subject to the same conditions.

With software version 1.1 the output pulse duration can be forced to a minimum value of 20ms, regardless of the input pulse duration. If jumper J1 is shorted, the output will be on for at least 20 ms. Without jumper J1 shorted, the minimum output pulse duration is 1.5 ms.

The maximum output pulse duration is 30 s. This is the maximum detection time explained in paragraph 3.1. After 30s the interface is freshly adjusted and ready to detect a new load.

### 3.2.3 Jumper Settings

When jumper J1 is shorted, during reset, the trigger output on time is forced to a minimum of 20 ms. This feature does not work in software versions prior to 1.1.

Shorting jumper J2 sets the baud rate of the RS-232 interface from 9600Bd to 19200Bd.

### 3.2.4 Status Outputs

The status outputs are the six status LEDs and four optocoupler outputs on the system terminal block. In spite of the common labeling of some of them their behavior is not the same. This might be confusing at first but provides maximum convenience during operation.

#### 3.2.4.1 Status LEDs

There are three groups of status LEDs: TRGx, AUXx and ERRx. The TRGx LEDs show the trigger status of both channels, the red ERRx LEDs report error conditions and the AUXx show other conditions or events.

The TRGx LEDs correspond to one channel each. During initialization when the interface is adjusting itself they are flashing up to ten times, giving a measure of the sensor loss (see also paragraph 3.2.1 on page 15). They are on if the respective channel is ready to detect load and go off when load a load is detected or when an error occurs.

The ERRx LEDs are also associated to one channel each. During initialization they are flashing. If the controller cannot transmit enough light through a sensor the respective ERR LED is switched on continuously.

The AUX1 LED is on when both channels are detecting load, otherwise it is off.

The AUX2 LED comes on when either of the channels has an error condition and its ERR LED is on continuously. This might seem redundant, but the AUX2 LED is switched on and off in accordance with the AUX2 optocoupler output which reports an error (see below). This is convenient for troubleshooting purposes.

### 3.2.4.2 System Terminal Block

The system terminal block has four optocoupler outputs, divided into two groups: TRGx and AUXx. The TRGx outputs become conductive (ON condition) when there is load detected by the respective channel. **This is inverse to the TRGx LEDs!**

The AUXx optocoupler outputs follow the AUXx LEDs. The AUX1 output comes on when both of the TRGx outputs are on and the AUX2 output comes on when there is an error condition regardless at what channel.

### 3.2.4.3 Status Table

The table below is to summarize the different states the two channels can be in and the according behavior of the status outputs.

Status		Status LEDs						Optocoupler Outputs			
Channel1	Channel2	TRG1	TRG2	AUX1	AUX2	ERR1	ERR2	TRG1	TRG2	AUX1	AUX2
adjust	Adjust	*	*			flash	flash				
adjust	Ready	*	ON			flash					
adjust	Detect	*				flash			ON		
adjust	Error	*			ON	flash	ON				ON
ready	Adjust	ON	*				flash				
ready	Ready	ON	ON								
ready	Detect	ON							ON		
ready	Error	ON			ON		ON				ON
detect	Adjust		*				flash	ON			
detect	Ready		ON					ON			
detect	Detect			ON				ON	ON	ON	
detect	Error				ON		ON	ON			ON
error	Adjust		*		ON	ON	flash				ON
error	Ready		ON		ON	ON					ON
error	Detect				ON	ON			ON		ON
error	Error				ON	ON	ON				ON

\* : may flash during startup

### 3.2.5 RS-232 Interface

#### 3.2.5.1 General

The RS-232 interface of the MD-220 allows bi-directional communication with a host computer or a passive RS-232 device. It can be used for debugging and troubleshooting purposes as well as for setting up simple measuring systems. Please refer to paragraph 2.5 for the wiring of the connector.

#### 3.2.5.2 Comm Parameters

The standard comm parameters of the MD-220's RS-232 interface are 9600,8,N,1 (9600 Baud, 8 data bits, 1 stop bit, no parity). By shorting jumper J2, the baud rate is switched to 19200 Baud.

#### 3.2.5.3 Output Modes

There are several different possibilities to output useful data via RS-232. Switching between these output modes is done by sending single characters to the MD-220. The easiest way to do so is by using the keyboard on a PC running a terminal program.

##### 3.2.5.3.1 Voltage Mode

The Voltage Mode is the default mode at startup. While operating in another mode, the MD-220 enters the Voltage Mode when it receives a "v" or a "V". The interface then continuously reports its analog voltages, monitor voltages and thresholds. The message format is

X	X	X		X	X	X		X	X	X		X	X	X		X	X	X	CR	LF																
Channel 1 Analog Voltage, 3 digits hex			blank (20h)			Channel 1 Trigger Threshold, 3 digits hex			blank (20h)			Channel 1 Monitor Voltage 3 digits hex			blank (20h)			Channel 2 Analog Voltage 3 digits hex			blank (20h)			Channel 2 Trigger Threshold 3 digits hex			blank (20h)			Channel 2 Monitor Voltage 3 digits hex			Carriage Return (0Dh)		Line Feed (0Ah)	

All voltages are given in 12 bits ADC digits with a maximum value of FFFh (=4095) corresponding to a voltage of approximately 10V.

This output can be logged and later processed into suitable diagrams. When reading it into Microsoft EXCEL all fields must explicitly be marked as text format, otherwise numbers that do not contain any letters will be imported as decimal numbers.

### 3.2.5.3.2 Percent Mode

Percent mode is entered as soon as the MD-220 receives a "p" or a "P". It continuously reports the relative difference of the registered light power to that which is related to the currently established trigger threshold. The message format is

+	X	X	X		+	X	X	X	CR	LF
Sign ("+" or "-")					Sign ("+" or "-")				Carriage Return (0Dh)	Line Feed (0Ah)
Channel 1 Relative Signal 3 digits hex				blank (20h)	Channel 2 Relative Signal 3 digits hex					

The values are given in units of 0.1%. For example if the trigger threshold is set to 0.8% the values issued should be around "+008". As soon as the sign changes to "-" the interface will trigger.

This output mode allows for quick judgment of the measuring effect – especially the quality of the sensor setup – on-site without any computations. The signal resolution is significantly lower than that obtained from voltage data, but the messages are shorter so there is a higher time resolution in percent mode.

### 3.2.5.3.3 Transmittance Mode

With this output mode a host computer checks the loss of connected sensors. This cannot be derived from the analog and monitor voltages alone because these do not contain any information about the light power fed into the sensors. When a "t" or a "T" is received the MD-220 continuously reports the sensor transmittances with two four-digit hex numbers every line. The message format is

X	X	X	X		X	X	X	X	CR	LF
Channel 1 Transmittance 4 digits hex				blank (20h)	Channel 2 Transmittance 4 digits hex				Carriage Return (0Dh)	Line Feed (0Ah)

Unlike the logarithmic sensor loss which is given in dB and signaled by the TRGx LEDs on startup the sensor transmittance is a linear quantity which is given in arbitrary units here. The theoretic dynamic range of the interface is represented by values from 4h (4) to D8Fh (3471). It must be noted that errors are not signaled exactly when these values are exceeded because the conditions which define an error are not derived from this quantity.

### 3.2.5.3.4 Status Mode

This is a non-continuous output mode. It is entered on receipt of an "s" or an "S". The status of each channel of the MD-220 is internally described by two status bytes. Every time one of these four bytes changes a status message is issued. The message format is

X	X	X		X	X	X		X	X	X	X		X	X	X	X	CR	LF
Second count 3 digits hex			blank (20h)	Millisecond count 3 digits hex			blank (20h)	Channel 1 Status 4 digits hex				blank (20h)	Channel 2 Status 4 digits hex				Carriage Return (0Dh)	Line Feed (0Ah)

The first 3-digit hex number gives the number of seconds elapsed since the last reset. It is reset to zero every hour (its maximum value is E0Fh (=3599)). The second number is the number of milliseconds which is zeroed when the second count changes. Its maximum value is therefore 3E7h (=999).

The following two 4-digit hex numbers give bit-wise information about the status of each channel. Their meaning is as follows:

Bit 0 / LSB	TRIGGERED	Channel is currently detecting load, trigger signal is on
Bit 1	TRG_TIMEOUT	Trigger signal has been on for 30 s and will now be cleared, trigger threshold will be reset
Bit 2	TRG_INHIBIT	Trigger signal inhibited
Bit 3		reserved
Bit 4	ANALOG_LOW	ANAx voltage requires upward adjustment
Bit 5	ANALOG_HIGH	ANAx voltage requires downward adjustment
Bit 6	ANALOG_DOWN	ANAx voltage too low for proper triggering – Error
Bit 7	ANALOG_CLIPPED	ANAx voltage too high for proper triggering – Error
Bit 8	THRSH_NOUPDATE	Updating of trigger threshold is inhibited due to expected load detection
Bit 9	THRSH_TIMEOUT	Trigger threshold has not been updated for 30 s and will be updated now
Bit 10	THRSH_RESET	Trigger threshold is considered to be wrong and will immediately be set to 0.8% below current light level
Bit 11	THRSH_NINIT	Trigger threshold not initialized, trigger signal inhibited
Bit 12	SENSOR_HIGHLOSS	Sensor loss above dynamic range – Error
Bit 13	SENSOR_LOWLOSS	Sensor loss below dynamic range – Error
Bit 14		reserved
Bit 15 / MSB		reserved

The very first status message is transmitted immediately after entering status mode but this does not mean that something has changed at that moment. Every additional "s" or "S" triggers a new message without status change.

### 3.2.5.3.5 Off Mode

On receipt of an "o", an "O" or a "0" (zero) the transmission of any messages is inhibited. The interface still receives characters and can be switched to another mode at any time.

### 3.2.5.3.6 Software Version Query

When the MD-220 receives a "q" or a "Q" a short copyright notice including name and version number of the loaded software is issued. Enter off mode or status mode before querying the software version.

If this does not work the software loaded is MA110STD v1.0.

### 3.2.5.3.7 Special Output Modes

When one of the characters 'F', 'C' or 'Y' is received the interface enters special output modes which are meant for laboratory use or troubleshooting in special cases. The output consists entirely of printable characters, but special software is required to decode it.

### 3.2.5.4 Commands

Aside from the previously described characters which only change the output sent via the RS-232 interface there are also characters which directly affect the behavior of the MD-220.

#### 3.2.5.4.1 System Reset Command

On receipt of a capital 'R' a software reset is initiated just as if the reset button had been pressed. This is done by sending the controller into a non-terminated loop and having the watchdog timer trigger the reset. Consequently, it may take up to 4 ms until it is executed. This command can also be used to verify the watchdog function.

#### 3.2.5.4.2 Threshold Reset Commands

When the MD-220 receives a '1' or a '2' the trigger threshold of the respective channel is immediately reset. This must not be confused with a system reset which causes the complete startup initialization process to be performed. Here the interface only accepts the current light level as new no-load value and establishes its trigger threshold 0.8% below it.

The threshold management algorithm used with MA220STD v1.2 is sophisticated. This can not keep the interface from hanging if during load detection something reduces the sensor's transmittance permanently. The trigger signal will then remain on for 30 s and the interface will be unable to detect any new load cycle during this time.

The threshold reset command enables a host computer to tell the MD-220 that there is currently no load on the sensor. This is useful to clear the trigger signal in situations where the interface is suspected or known to be hanging. The command can also be given by the host computer if it knows there can be no load on the sensor from another detector (i.e. a inductive loop). Using this feature will make malfunctions or anomalies virtually impossible.

The command should not be used to acknowledge a trigger signal by clearing it since the load may not have reached its maximum value yet. If the trigger threshold is reset while the load increases a second trigger signal might be erroneously generated by the still increasing load.

---

Important notice

All the information contained herein is believed to be accurate and reliable. However, SENSOR LINE assumes no responsibility for its use or for any infringements of patents or other rights of third parties that may result from its use. No license is granted by implication or otherwise under any patent rights of SENSOR LINE GmbH.

SENSORLINE shall not be liable for any special, incidental or consequential damages related to the use of the product. Our product guides and instructions are continuously updated. Make sure you have got the latest edition. For further information contact the SENSOR LINE technical support team.

---