



Contents

	page
1 General Description	2
2 Mode of Operation	2
3 Induction Loop	4
4 Laying of the Loop	5
4.1 Casting Compound	6
5 Feeder of the Loop	7
6 Geometry of the Loop	8
7 Special Areas of Use	9
7.1 Detection of Two-Wheeled Vehicles	9
7.2 Tram and Train	10
7.3 Automatic Transportation Systems	10
8 Special Cases	11
8.1 Strong Iron Armour	11
8.2 Electric Heating Blankets	12
8.3 Laying Under Interlocking Stone Paving	12
9 Direction Logic	13
10 Advices for the Overvoltage Protection	14

1 General Description

Induction pulse generators are the most used devices for the detection of vehicles of all kind. The induction loop as sensor of these cheap devices is characterized by its robust and weather-independent structure.

These advices for the laying of loops relate to the following areas of use:

area gates:	automatic opening and closing of gates, shutters, barriers, etc.
parking lots:	detection of single parking spaces control of barriers counting in parking garages
rail-bound vehicles:	opening and closing of hall gates general detection for other control purposes

The Weiss-Electronic induction pulse generators include the following features:

- microprocessor control
- static holding time
- high sensitivity of max. 0.02% $\Delta f/f_0$
- multichannel version, max. 4 channels
- wide range of operation 10 μH - 2000 μH
- temperature compensation
- automatic adjustment

These characteristics are typical values. The characteristics in the technical data of each single device have to be taken care of.

2 Mode of Operation

The induction loop is the inductive part of an L-C oscillator. The loop inductivity and the capacity of the internal capacitor determine the resonance frequency f_0 of this resonating circuit. With some devices, the capacity of the capacitor and so the resonance frequency can be modified by switches resp. jumpers.

Other detectors can be set to different measuring frequencies via Software.

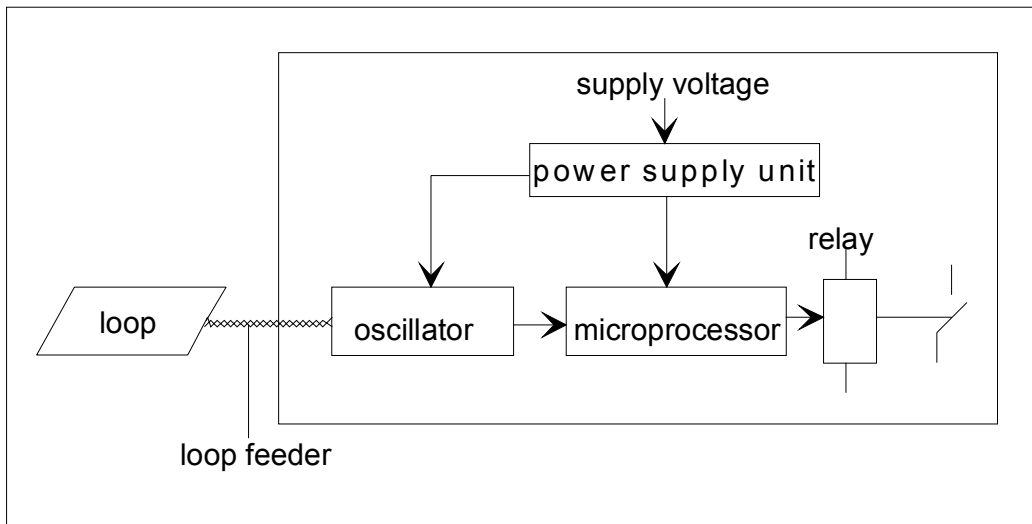

Rule for the induction loop is:
 The lower the inductivity the higher the frequency f_o .

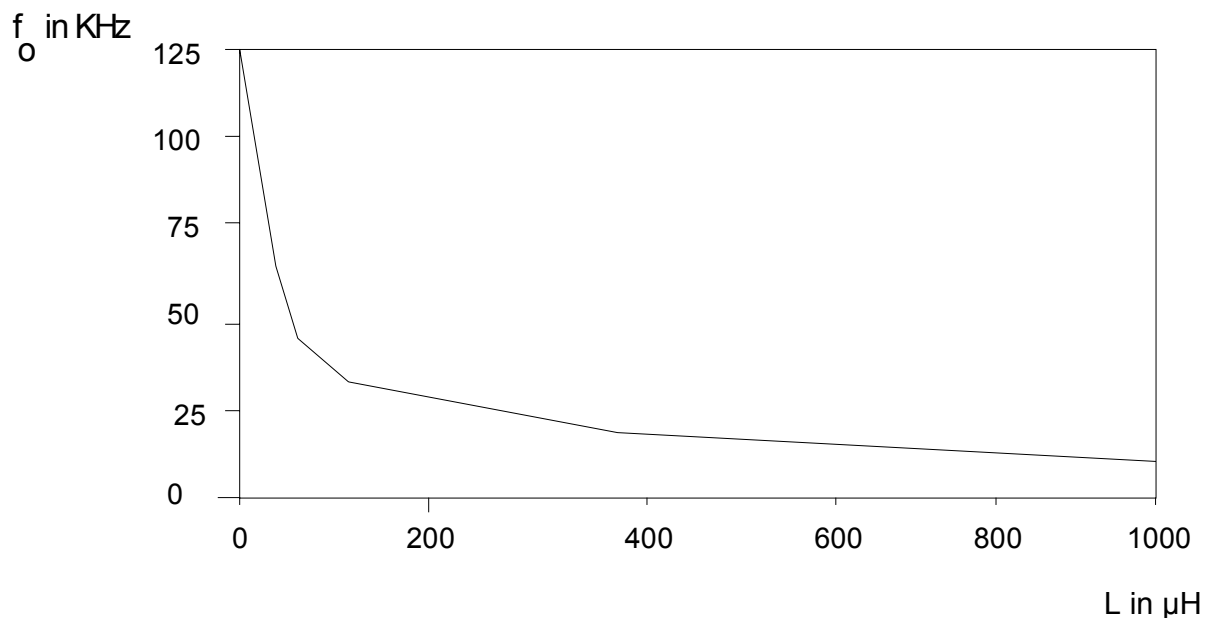

Example of the dependence f_o on L

At first, the functioning of the unattenuated loop is explained.
 A magnetic alternating field forms around the loop flow through by the electric current.

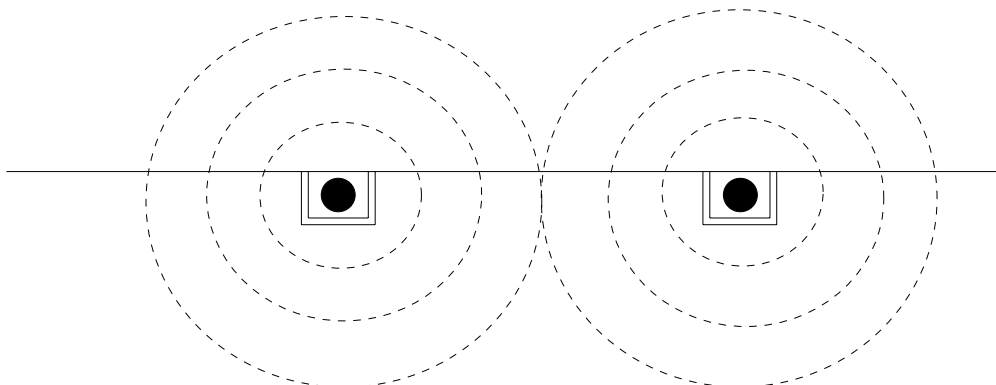

At the same time the magnetic field lines close on the shortest way.

Now a vehicle drives on the induction loop.

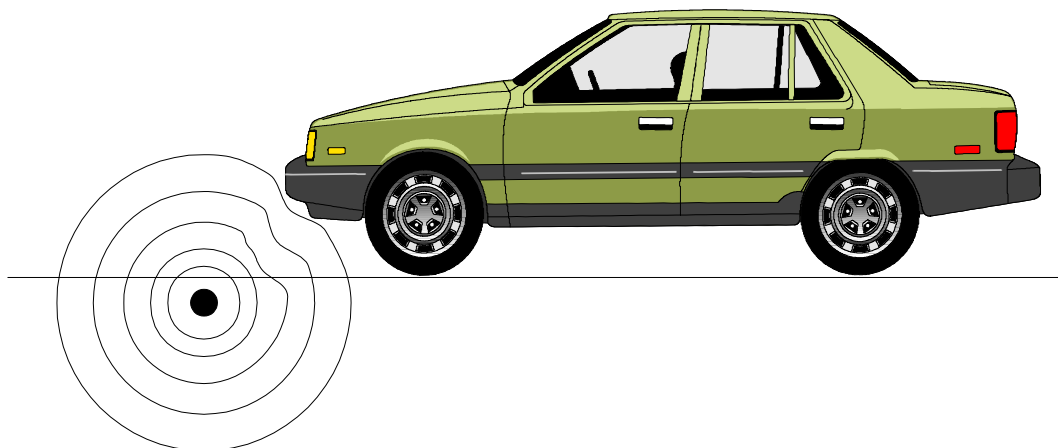

In the vehicle's chassis, currents are induced by the alternating field of the loop. These currents form a magnetic field themselves and have a countereffect on the original field. The field lines of the induction loops are diverted by this magnetic field and do not close on the shortest way any more.

As the inductivity gets smaller with a growing field line length, the inductivity of the loop decreases. The frequency gets higher. The microprocessor detects this frequency change.

With a frequency change bigger than the switching threshold, the microprocessor switches on the relay contact of the detector. The switching threshold is set by the sensitivity. With a high sensitivity, a low switching threshold results. With a low sensitivity, a high switching threshold results. The sensitivity should not be set higher than necessary.

Very slow changes of the loop frequency (e.g. caused by temperature changes) do not lead to a switching.

3 Induction Loop

In most of the possible uses, the induction loop is laid in a quadratic or rectangular form. According to the loop's circumference, a different number of turns has to be put into the loop slot.

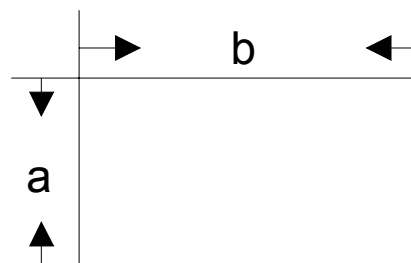

The table shows the requested number of turns at different circumference ranges (for a side ratio of $b:a = 3:1$).

circumference	number of turns	inductivity
4 - 5 m	5	180 - 200 μH
5 - 6 m	4	130 - 160 μH
6 - 15 m	3	140 - 150 μH
15 - 25 m	2	85 - 130 μH

The inductivity values in the above table are in the optimum range of operation of the detector (80 μ H - 300 μ H). In this range the maximum sensitivity is achieved.

4 Laying of the Loop

To put the loop into the ground covering, at first a slot is being cut into the concrete or asphalt with a diamond disk. This slot should be approx. 40 mm - 70 mm deep and 5 mm - 8 mm wide.

The next step will be the cleaning of the slot. Dampness has to be avoided with that. After that, the loop wire can be laid in.

As loop wire, a standard flexible and isolated copper line HO7V-K1.5 (NYAF 1.5 mm²) can be used.

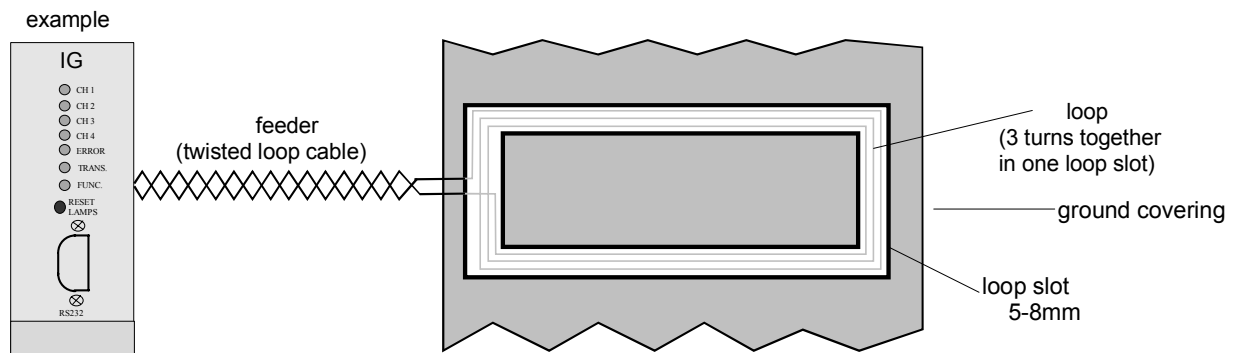

If the loop is casted with hot bitumen, a temperature-resistant loop wire has to be used.

In the areas Door & Gate and Barriers, a diagonal joint shall be cut at the edges with an angle of 45°, through which the loop wire is led. So, not too much strain is put on the edges of the loop cable.

In the Highway Area, a rounding off of the sharp joint edges by drilling is advisable. There is the danger of breaking edges because of the strain by passing vehicles. A drilling for this area is therefore better.

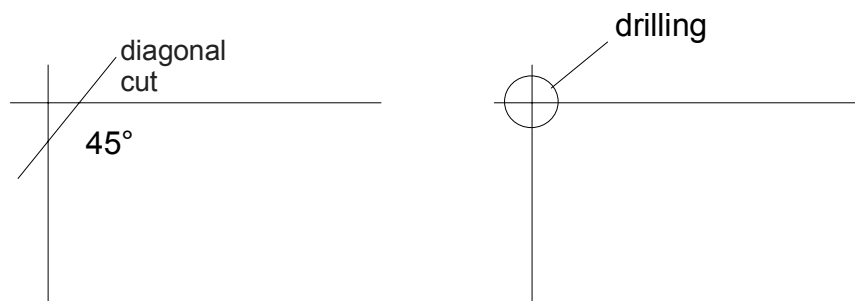

Attention should be paid to the following points when laying induction loops:

- The ground covering has to be continuously solid and without cracks.
 - A diagonal joint has to be cut at the joint edges or the edge has to be drilled.
 - When laying the loop wires into the slot, one should pay special attention to the edges.
 - The loop wire must not show any isolation damages.
 - The loop wire may not jut out of any part of the slot, since the isolation will otherwise be destroyed or the wire will tear. When laying in the loop wire, it is better to protect it from washing up with wooden wedge during the casting.
 - The loop wires may not move after the casting.
- The loop slot has to be clean and dry before casting.
- With an L-Meter or a Weiss Electronic diagnostic device, the loop inductivity should be measured.
 - The insulation resistance is to be measured with an insulation testing device against earth (values > 500 M Ω at 500 V measurement voltage and recently installed loops)

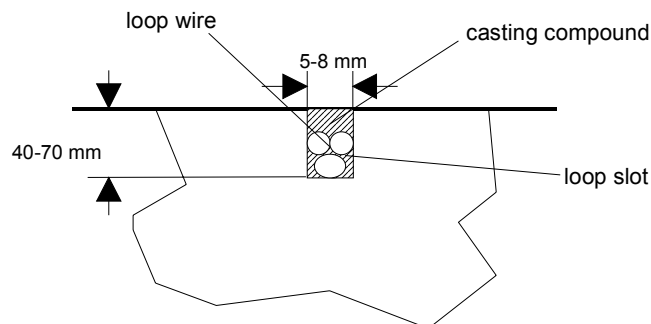

4.1 Casting Compound

Cold casting compound

In many cases, a two-component casting compound on a synthetic resin basis is used. This casting compound has to remain in permanent flexibility after the casting so that the casting compound does not get crumbly, even in a cold environment.

Attention:

The loop cut has to be casted in a dry and dust-free way. Only just as much of the casting compound should be used as is needed to fill the loop slot.

Hot casting compound

When working with hot casting compound, the same points as with the cold casting compound should be paid attention to.

Attention:

With hot casting compound, only copper alloy wire or wire with heat-resistant insulation is to be used!

If cable with non-heat-resistant insulation shall be used, glass sand has to be filled in the slot after the laying of the loop wire (approx. 1 cm), in order to protect it from the heat of the casting compound.

5 Feeder of the Loop

The loop feeder is often the reason for occurring detector failures.

Attention has to be paid to the following points when operating and laying the loops:

- The two loop feeder cables have to be twisted. Approx. 50 turns per m. with NYAF.
- The loop feeder should not be laid parallel to other electric circuits. A space of approx. 10 cm to all nearby lines has to be kept.
- The loop feeder has to be twisted and installed carefully in the cabinet too.
- Loop feeders of different detectors also have to be laid by keeping space.
- Do not lay the feeder cable through the loop slot of a nearby loop.

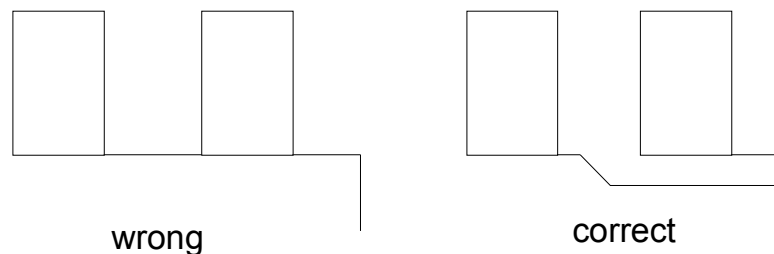

- Protect the feeder cable against mechanical damage.
- The ohmic resistance (feeder cable plus loop) may not be too high in relation to the loop inductivity. Corresponding information can be found in the data sheets of the detectors.

In general: The higher the ohmic resistance, the higher the loop inductivity has to be selected.

6 Geometry of the Loop

With certain applications, the inductivity also depends on the geometry of the loop. The loop geometry has to be adjusted to the corresponding case of application. So, a loop with a length of 5 m and a width of 0.2 m is very unfavourable. The width of the loop has to be adjusted to the vehicle width. The highest sensitivity will be achieved if the vehicle is a little bit wider than the loop.

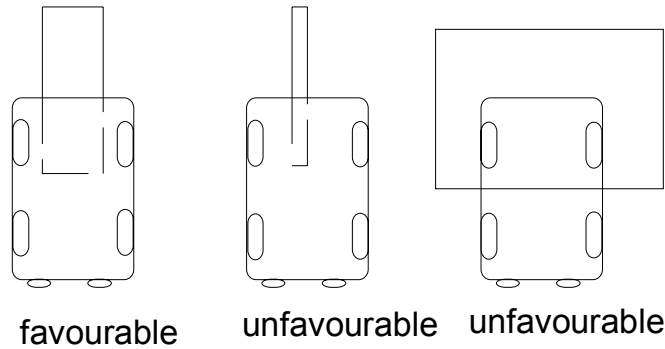

Nearby loops of different detectors have to be laid with a space of 1 m to 1.5 m (depending on the loop size). Interfering frequencies from loop to loop become smaller.

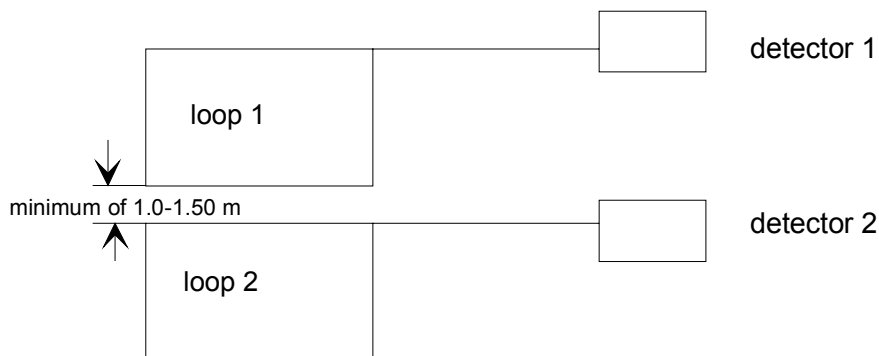

If multichannel detectors are used, the loops of one device can be laid with little space or even in an interlocking way.

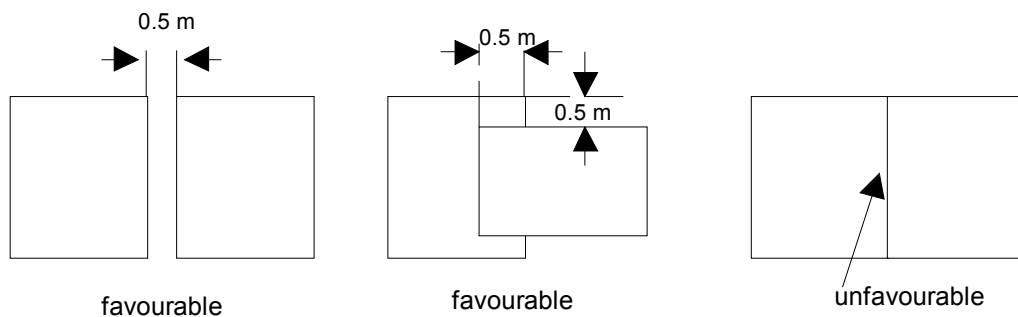

Special forms like T-double-angles, etc. can be realized.

Special forms

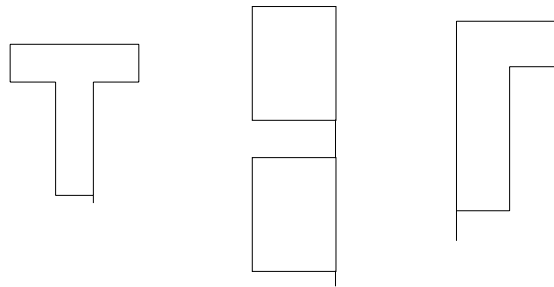

A loop should not be laid in a too narrow or small way, otherwise the detection height will decrease. This has to be especially taken into account with high clearance vehicles (e.g. lorries) or small attenuation space (e.g. bicycles). Rule: a car leads to an approx. three times higher attenuation compared to a lorry.

To avoid a fading-out in the axle area of lorries with trailers, the loop should have a corresponding length.

7 Special Areas of Use

7.1 Detection of Two-Wheeled Vehicles

Two-wheeled vehicles only cause a minor frequency change which lies, in most of the possible uses, just above the switching threshold.

Attention:

The attenuation is mostly not sufficient to signal a safe permanent occupation. Because of that, the loop should possibly be laid in an angle of 45° to the travel direction. This will lead to an increase in sensitivity. If iron armour is under the loop, in most cases the two-wheeled vehicle detection is no longer guaranteed. Pilot tests with the loop diagnosis device (SDG2) have to be carried out here.

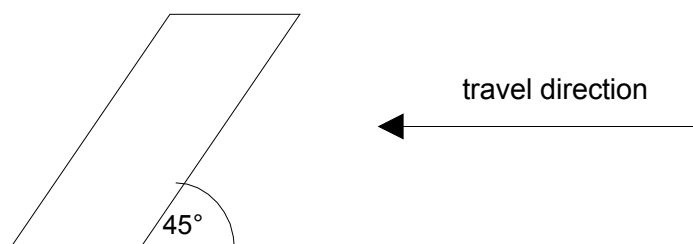

7.2 Tram and Train

To detect rail-bound vehicles the loop is laid between the tracks.

Attention:

The distance to the track is a minimum of 20 cm (pre-attenuation!).

The loop is laid in the form of an eight so that interference voltages of currents in the tracks compensate in the loop circuit.

The loop has to be firmly embedded, a change of position through vibration will lead to interferences. Because of the high clearance of these vehicles, the only possibility often is an axle detection.

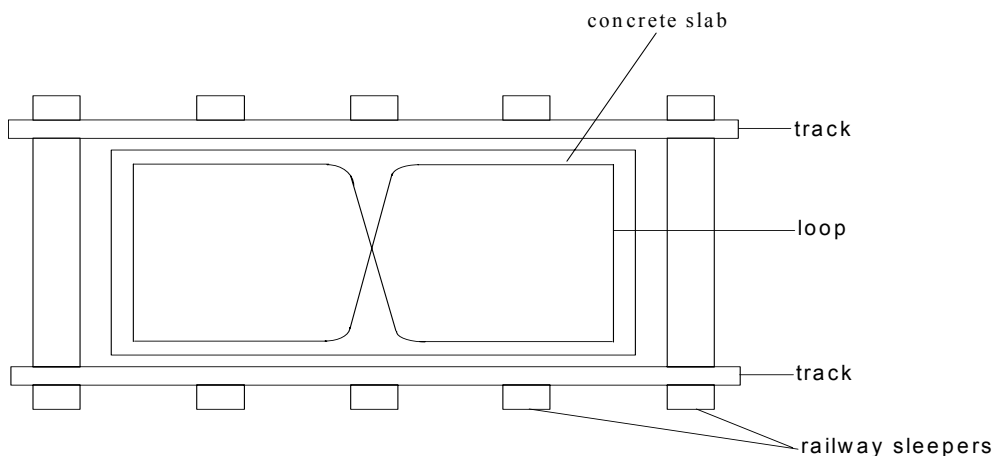

7.3 Automatic Transportation Systems

In conducted transportation systems the vehicles are detected by induction loops with the help of contact wires at planned positions.

Attention:

The loop has to be laid symmetrically to the guiding wire (neutralization of the induced interference voltage).

Do not lay the loop feeder into the slot of the guiding wire.

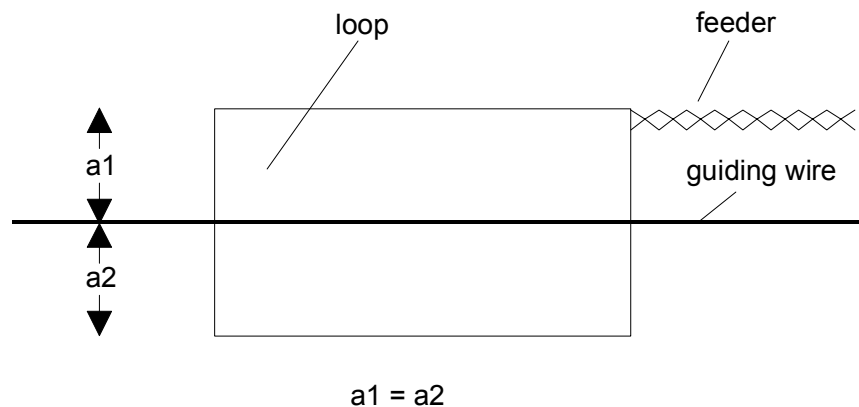

8 Special Cases

8.1 Strong Iron Armour

Iron armour in the ground decreases the sensitivity of the induction loop. The smaller the distance of the loop to the iron armour, the smaller the sensitivity gets.

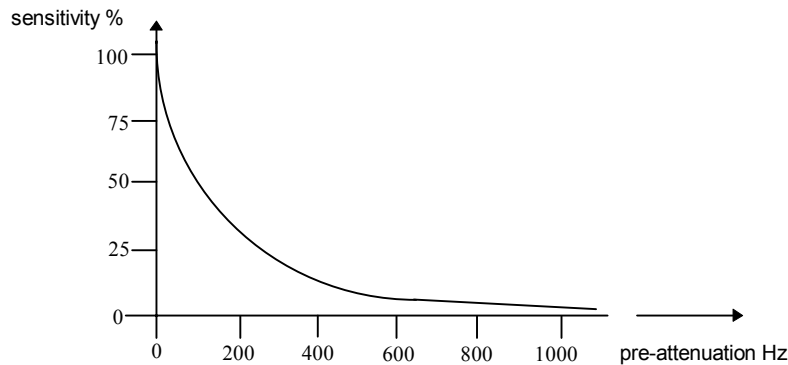

The curve of the graphical representation shows how the switching level decreases with increasing attenuation.

100% switching level corresponds to the unattenuated loop without iron armour.

Especially with lorries, the pre-attenuation has to be taken into account because of their high ground clearance.

Here should be proceeded as follows before the final laying of the loops:

- a) If a loop diagnosis device (SDG2) for the measurement of the pre-attenuation is available:
 - Measure the level of pre-attenuation with this measuring device and the reference loop
 - For the laying of the loop measure out a range in which the pre-attenuation is relatively small
 - After that, lay a provisional loop of the desired size on the ground and fix it with adhesive tape
 - Connect the diagnostic device to the loop. The detector must not be connected
 - Measure alignment frequency of the loop with the loop diagnosis device
 - Drive on the loop with the respective vehicle.

Measure the frequency change level with the diagnostic device.

It is a measure of the sensitivity. The Weiss-detectors switch in the highest level of sensitivity at $\Delta f/f_0 = 0.02\% - 0.01\%$

- To detect a vehicle safely, frequency changes in the order of $\Delta f/f_0 \approx 0.2 - 0.5\%$ are to be aimed at. This has to be taken into account especially with induction loops that have a security function

RS
RS-S

1.80 m * 0.80 m, 10 m feeder
customized type

- Afterwards:
- Fill in sand layer and compress it
 - Put in stones and vibrate
 - Measure insulation resistance
 - Measure inductivity
 - Check function

9 Direction Logic

The microprocessor-controlled induction pulse generator in 2- and 4-channel version can be delivered with direction logic.

For that, 2 channels (channels 1 and 2, as well as channels 3 and 4) respectively form a direction logic.

Applications for Direction Logic

- direction-dependent control of barriers, garage driveways and gate systems
- entry and exit countings in parking garages
- detection of wrong-way drivers

Function

The direction logic will be explained using an example:

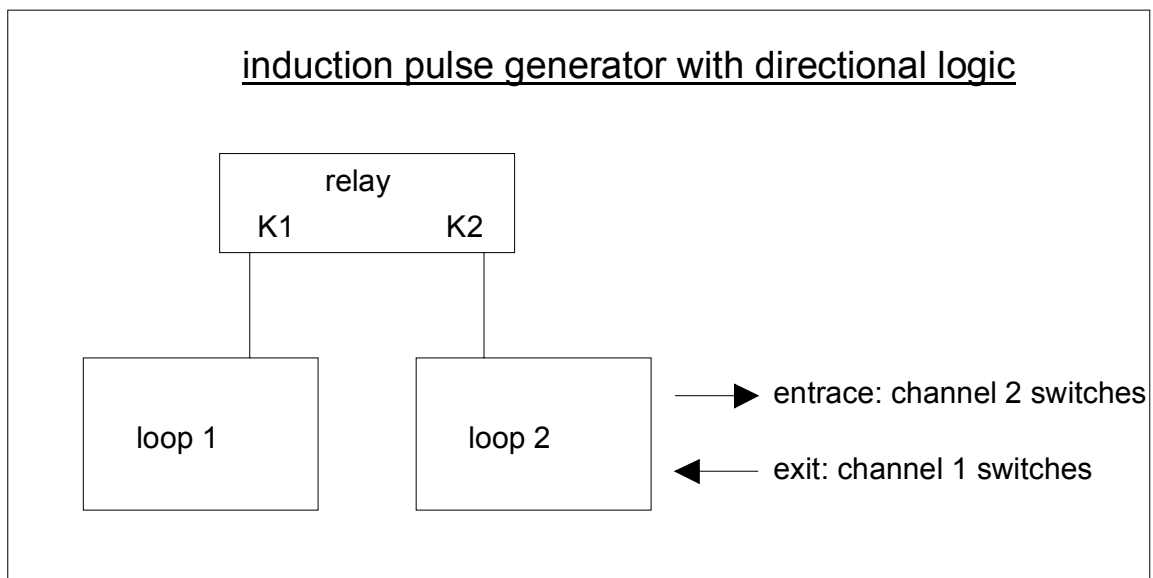

After the attenuation of loop 1, this is recorded in the detector, but no output is switched until now. Only when loop 2 is also simultaneously attenuated, the relay of the second channel switches on and it stays switched-on as long as loop 2 will be released again.

In the other direction (in this case exit), the switching process happens in reverse order. Here, relay channel 1 switches on when both loops are attenuated and it stays switched-on as long as loop 1 will be released again.

A directional detection is realized accordingly with the channels 3 and 4.

Laying of the Loop with Direction Logic

Both loops of a direction logic have to be so close together that every vehicle which has to be detected attenuates both loops.

In this case the loops can also be laid in an interlocking way.

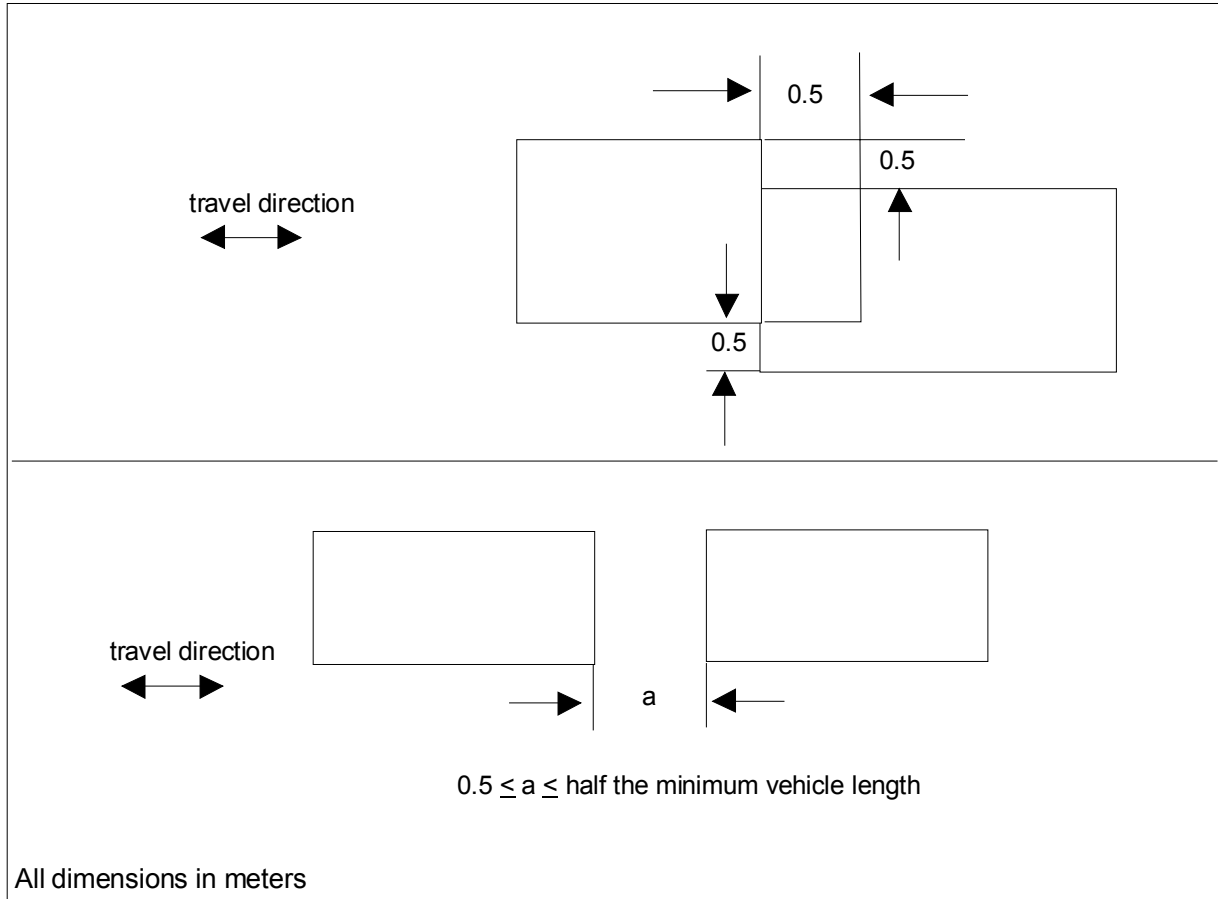

10 Advices for the Overvoltage Protection

It is advisable to protect the loop feeders near the rack from overvoltages.

Since the induction loops may be strained neither induction- nor capacity-wise, here only gas release lines can be used. Here, the loop connective field FP_V1_2 of Weiss-Electronic is advisable. One loop connective field per 4-channel detector is required.